



DW-D1255-80CG
1.25Gbps 80km GBIC Optical Transceiver

Features

- ◆ Dual data-rate of 1.25Gbps/1.0625Gbps operation
- ◆ 1550nm DFB laser and PIN photodetector for 80km transmission
- ◆ Duplex SC optical interface
- ◆ Standard serial ID information compatible with SFF-8053
- ◆ +3.3V/5Vsingle power supply
- ◆ RoHS Compliant
- ◆ Operating case temperature: 0 to +70°C



Applications

- ◆ Switch to Switch interface
- ◆ Switched backplane applications
- ◆ Router/Server interface
- ◆ Other optical transmission systems

Description

The GBIC transceiver is high performance, cost effective module supporting dual data-rate of 1.25Gbps/1.0625Gbps and from 40km transmission distance with SMF.

The transceiver consists of two sections: The transmitter section incorporates a DFB laser. And the receiver section consists of a PIN photodiode integrated with a trans-impedance preamplifier (TIA). All modules satisfy class I laser safety requirements.

The optical output can be disabled by a TTL logic high-level input of Tx Disable. Tx Fault is provided to indicate degradation of the laser. Loss of signal (LOS) output is provided to indicate the loss of an input optical signal of receiver.

The standard serial ID information Compatible with GBIC MSA describes the transceiver's capabilities, standard interfaces, manufacturer and other information. The host equipment can access this information via the two-wire serial CMOS EEPROM protocol. For further information, please refer to SFF-8053



Absolute Maximum Ratings

Stress in excess of the maximum absolute ratings can cause permanent damage to the module.

Table 1 - Absolute Maximum Ratings

Parameter	Symbol	Min	Typical	Max	Unit
Maximum Supply Voltage	V _{cc}	0.5	-	4.5	V
Storage Temperature	T _s	-40	-	+85	°C
Relative Humidity	R _H	0	-	+85	%

Recommended Operating Conditions

Table2 - Recommended Operating Conditions

Parameter	Symbol	Min	Typical	Max	Unit
Operating Case Temperature	T _c	0	-	+70	°C
Power Supply Voltage	V _{cc}	3.1		5.5	v
Power Supply Current	I _{cc}			300	mA
Data Rate	Gigabit Ethernet		1.25		Gbps
	Fibre Channel		1.0625		

**Optical and Electrical Characteristics****DW-D1255-80CG: (1550nm DFB and PIN, 80km)****Table3 - Optical and Electrical Characteristics (Operating case temperature TC=25°C, VCC=3.3V)**

Parameter	Symbol	Min.	Typical	Max.	Unit	Notes	
Transmitter							
Centre Wavelength	λ_c	1530	1550	1570	nm		
Spectral Width (-20dB)	σ			1	nm		
Side Mode Suppression Ratio	SMSR	30			dB		
Average Output Power	P_{out}	0		+5	dBm	1	
Extinction Ratio	ER	9			dB		
Output Optical Eye		IEEE 802.3z and ANSI Fibre Channel compatible					2
Data Input Swing Differential	V_{IN}	200		2400	mV	3	
Input Differential Impedance	Z_{IN}	90	100	110	Ω		
TX Disable	Disable	2.0		Vcc	V		
	Enable	0		0.8	V		
TX Fault	Fault	2.0		Vcc+0.3	V		
	Normal	0		0.8	V		
Receiver							
Centre Wavelength	λ_c	1260		1580	nm		
Receiver Sensitivity				-22	dBm	4	
Receiver Overload		-3			dBm	4	
Optical Path Penalty				1	dB	5	
LOS De-Assert	LOS _D			-23	dBm		
LOS Assert	LOS _A	-30			dBm		
LOS Hysteresis		1		4	dB		
Data Output Swing Differential	V_{OUT}	600		1000	mV	6	

Notes:

1. The optical power is launched into SMF.
2. Measured with a PRBS 2⁷-1 test pattern @1250Mbps.
3. CML input, internally AC coupled and terminated.
4. Measured with a PRBS 2⁷-1 test pattern @1250Mbps, BER $\leq 1 \times 10^{-12}$.
5. Measured with a PRBS 2⁷-1 test pattern @1250Mbps, over 20km G.652 SMF, BER $\leq 1 \times 10^{-12}$.
6. Internally AC coupled.



EEPROM Section

The SFF-8053 defines a 256-byte memory map in EEPROM describing the transceiver's capabilities, standard interfaces, manufacturer, and other information, which is accessible over a 2 wire serial interface at the 8-bit address 1010000X (A0h).

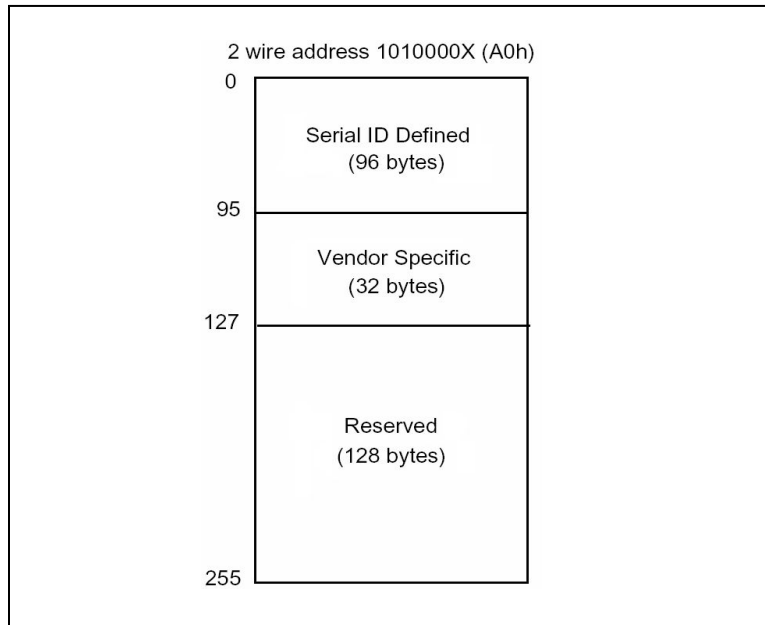

Pin Definitions

Pin Diagram

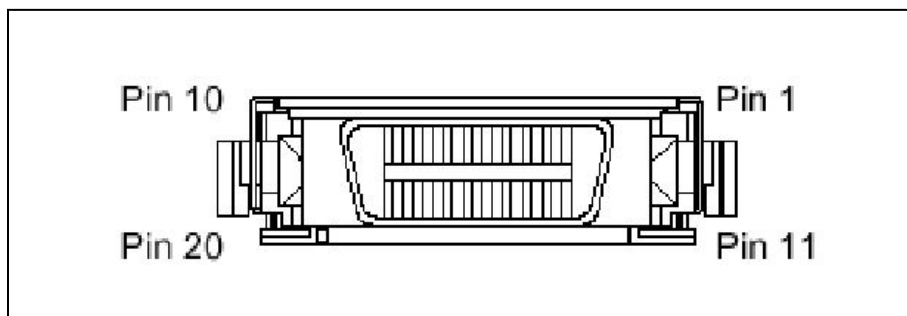

**Pin Descriptions**

Pin Name	Pin#	Name/Function	Signal Specification
Receiver signals			
RGND	2,3,11,14	Receiver Ground (may be connected with TGND in GBIC)	Ground, to GBIC
VDDR	15	Receiver +3.3/5 volt (may be connected with VDDT in GBIC)	Power, to GBIC
-RX_DAT	12	Receive Data, Differential PECL	High speed serial, from GBIC
+RX_DAT	13	Receive Data, Differential PECL	High speed serial, from GBIC
RX_LOS	1	Receiver Loss of Signal, logic high, open collector compatible, 4.7k to 10k Ω pull up to VDDT on host	Low speed, from GBIC
Transmitter signals			
TGND	8,9,17,20	Transmitter Ground (may be connected with RGND internally)	Ground, to GBIC
VDDT	16	Transmitter +3.3/5 volt (may be connected with VDDR in GBIC)	Power, to GBIC
-TX_DAT	18	Transmit Data, Differential PECL	High speed serial, to GBIC
+TX_DAT	19	Transmit Data, Differential PECL	High speed serial, to GBIC
TX_DISABLE	7	Transmitter Disable, logic high, open collector compatible, 4.7k to 10k Ω pull up to VDDT on GBIC	Low speed, to GBIC
TX_FAULT	10	Transmitter, Fault, logic high, open collector compatible, 4.7k to 10k Ω pull up to VDDT on host	Low speed, from GBIC
Control signals			
MOD_DEF(0)	4	TTL low, output	Please reference SFF-8053, Annex D; Module definition "4"
MOD_DEF(1)	5	SCL serial clock signal, input	
MOD_DEF(2)	6	SDA serial data signal, input/output	



Block Diagram of Transceiver

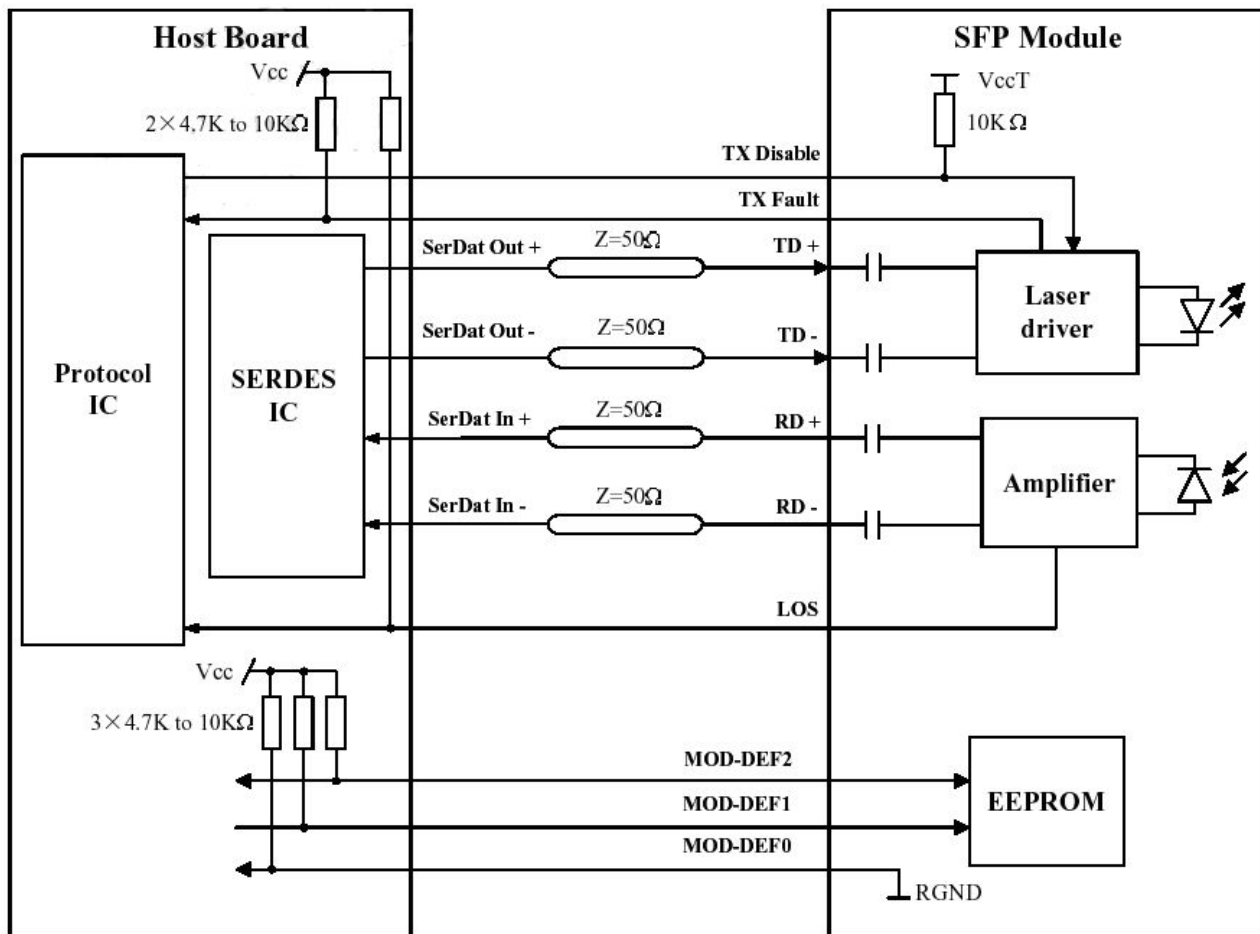



Ordering information

Part number	Product Description
DW-D1255-80CG	1550nm, 1.25Gbps, 80km, 0°C~+70°C

References

1. Gigabit Interface Converter (GBIC) Transceiver Multi-Source Agreement (MSA).
2. Telcordia GR-253-CORE and ITU-T G.957 Specifications.

Important Notice

Performance figures, data and any illustrative material provided in this data sheet are typical and must be specifically confirmed in writing by DONGWE before they become applicable to any particular order or contract. In accordance with the DONGWE policy of continuous improvement specifications may change without notice.

The publication of information in this data sheet does not imply freedom from patent or other protective rights of DONGWE or others. Further details are available from any DONGWE sales representative.